

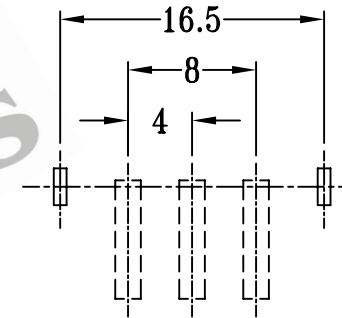

CAD FILE:

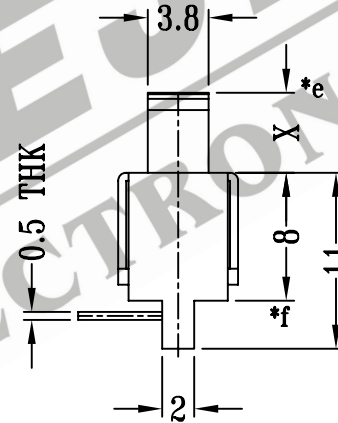

P.C.B LAYOUT

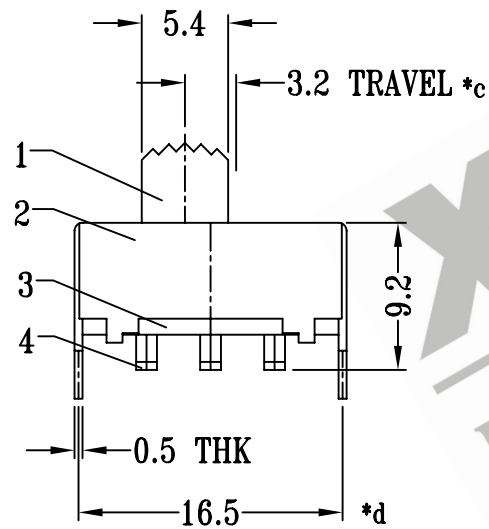
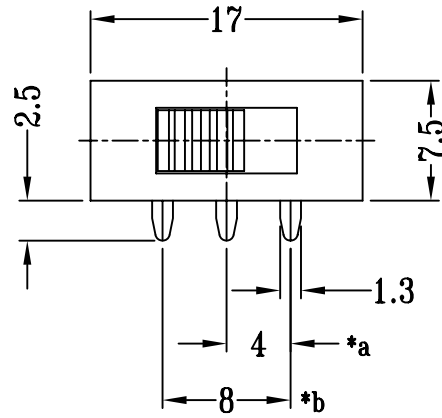
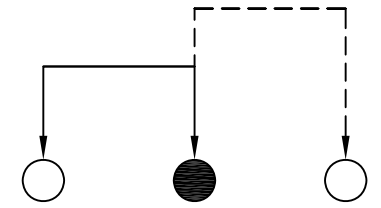

SCHEMATIC (NON-SHORTING)

注:带"\*"表示关键尺寸(6个)

NO.	PARTS	MATERIALS	Q'TY	FINISH	TOLERANCE UNLESS SPECIFIED	SHENZHEN XIEJIA ELECTRONICS CO.,LTD.				
8						TITLE : VERTICAL SLIDE SWITCH MODEL: SS-12F113 ALL MATERIALS MUST BE COMPLIANT TO ROHS				
7										ISSUE
6	SPRING	STEEL WIRE	1	TEMPER	WITHIN: 1.5±0.1mm OVER : 1.5±0.2mm	UNIT : mm		DRWG NO.: XJ-DR-SS12F113-00		
5	CONTACT CLIP	BRASS STRIP	1	Ag PLATED		SCALE: 2 : 1		DWN.	ZHOUYU	2004-4-26
4	TERMINAL	BRASS STRIP	3	Ag PLATED OVER Ni PLATED				CHK'D	FANGYING	2004-4-26
3	BASE	PHENOLIC RESIN	1	BLACK				APPD.	KANGXINAN	2004-4-26
2	FRAME	STEEL STRIP	1	Ni PLATED						
1	KNOB	POM	1	BLACK						